



# The Seating Philosophy

## LE SEDUTE DIRIGENZIALI

Le sedie da ufficio sono da sempre la nostra specialità. In queste pagine presentiamo una selezione di prodotti adatti a studi, sale riunioni e ambienti corporate in cui l'estetica contribuisce a esprimere molto più del gusto personale.

Nelle collezioni Alia, Viva e Aurelia l'ergonomia e il comfort vengono declinate utilizzando soluzioni realizzative e materiali di pregio.

### OUR EXECUTIVE SEATING

*Office chairs are our specialty. The following pages present a selection of executive seats that are suitable for offices, board rooms and corporate environments where design translates in much more than personal taste. The Alia, Viva and Aurelia collections represent a selection of high-end seats which guarantee ergonomics and comfort while making a statement of distinction.*

### NOS FAUTEUILS DE DIRECTION

*Les chaises de bureau ont toujours été notre spécialité. Dans ces pages, nous présentons une sélection de produits adaptées aux studios, salles de réunion, espaces de l'entreprise dans lesquels l'esthétique contribue à exprimer bien plus que le goût personnel. Les collections Alia, Viva et Aurelia représentent une sélection de fauteuils haut de gamme qui garantissent ergonomie et confort tout en faisant une déclaration de distinction.*

### DIE CHEFSESSEL

*Bürostühle waren schon immer unsere Besonderheit. Auf den folgenden Seiten finden Sie eine Auswahl an Chefsesseln, die für Büros, Sitzungsräume und Unternehmensumgebungen geeignet sind, in denen Design weit mehr als nur den persönlichen Geschmack zum Ausdruck bringt. Die Kollektionen Alia, Viva und Aurelia stellen eine Auswahl hochwertiger Sitzmöbel dar, die die Ergonomie und Komfort garantieren und gleichzeitig ein Status der Unterscheidung festlegen lassen.*

### NUESTROS ASIENTOS EJECUTIVOS

*Las sillas de oficina siempre han sido nuestra especialidad. En estas páginas presentamos una selección de productos adecuados para oficinas, salas de reuniones y entornos "corporate" donde la estética contribuye a expresar mucho más que el gusto personal. En las colecciones Alia, Viva y Aurelia, la ergonomía y el confort se expresan mediante soluciones de realización y materiales de alta calidad.*

 MOVING

# index

---

sedie  
*chairs*

7 ALIAC

29 ALIA**Top**

43 AURELIA

59 VIVA

ALIAC

# ALIAC



# ALIA C

design AMBOSTUDIO

AliaC è una sedia iconica e versatile. Le sue linee sono pulite, la struttura solida e i dettagli progettati per garantire comfort ed efficienza in ogni ambiente di lavoro. Il caratteristico traverso a forma di C sopra lo schienale aggiunge un'ulteriore nota elegante al suo design.

*AliaC is an iconic versatile seat. Its design is sinuous and the structure reliable, while the details are designed to offer comfort and productivity in any work space. It features a staple C-shaped backrest bar which adds an additional touch of elegance to it.*

Traverso a "C", alto livello di personalizzazione.  
Schienale medio o alto.

*C-shaped bar, highly customisable.  
Medium or high backrest.*



M

10



11



ALIAC



M

ALIAC





ALIAC



ALIAC



M

18





ALIAC



Scocca in rete  
*Mesh shell*

M

22

ALIAC



Scocca in rete tappezzata  
*Upholstered mesh shell*



Scocca tappezzata  
*Upholstered shell*

M

23



Scocca in rete con cuscini  
*Mesh shell with cushions*

# ALIAC

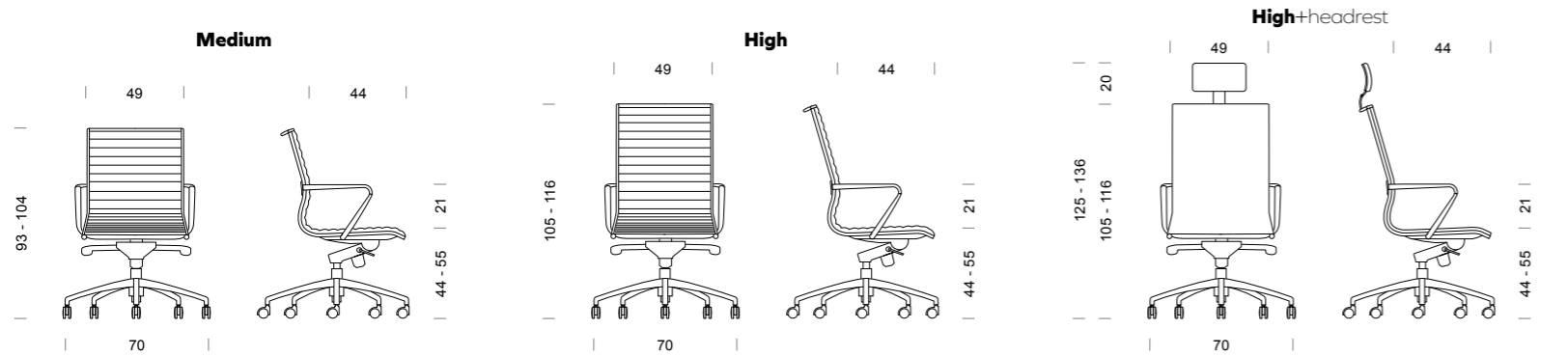

**SCHIENALE:** Monoscocca in tubo sagomato d'acciaio, Ø 25mm, finitura cromata (15µm), rete portante a vista.

**BACKREST:** Shaped steel tube monocoque, Ø 25mm, chromed finish (15µm), visible load bearing Mesh.

**DOSSIER:** Monocoque en tube d'acier Ø 25mm, finition chromée (15µm). Résille autoportante à vue.

**RÜCKENLEHNE:** Geförmte Stahlrohrschale, Ø 25mm, verchromt (15µm), mit Netzgespann.

**RESPALDO:** Monocasco en tubo de acero con forma, Ø 25 mm, acabado cromado (15 µm), malla.

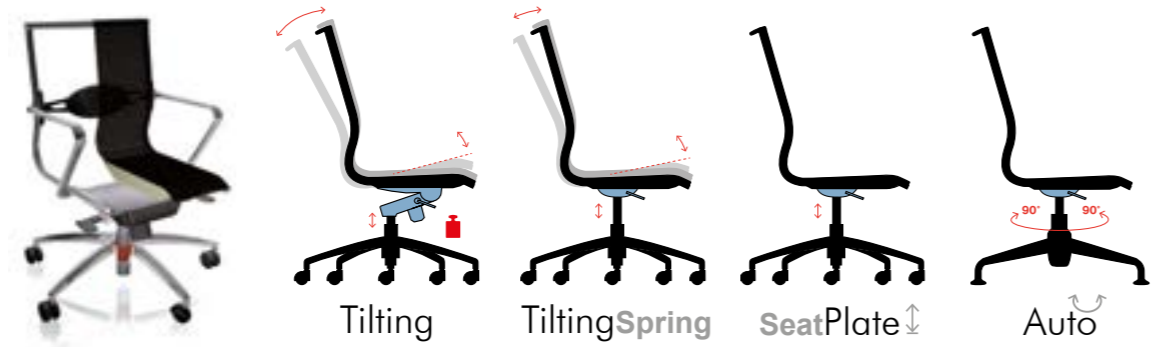

# ALIAC

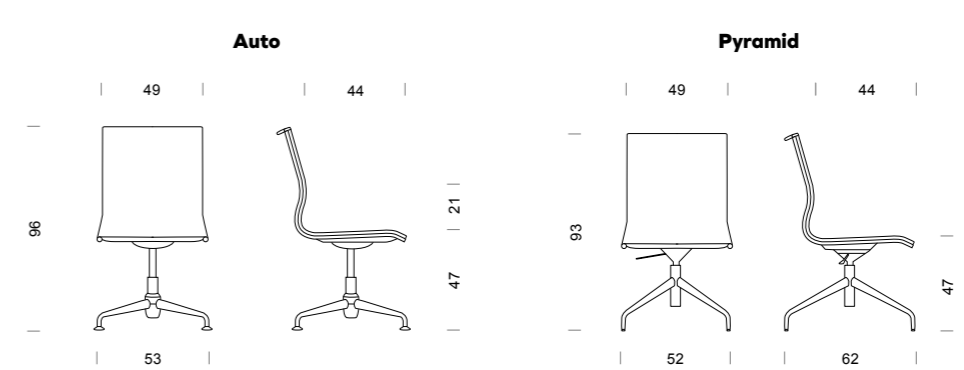

**A** Pressione sullo schienale di spalle e scapole  
Shoulders and scapulas pressure on backrest  
Pression des épaules et omoplates sur le dossier  
Druck von der Schulter und Schulterblatt auf der Rückenlehne  
Presión en la parte posterior de los hombros y omóplatos

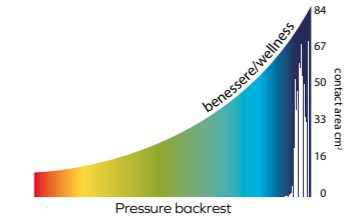

**B** Pressione dell'area sacrale su supporto lombare  
Sacrum pressure on lumbar support  
Pression sacrale sur le soutien lombaire  
Druck im Bereich Kreuzbein und Lendenwirbelstütze  
Presión del área sacra sobre soporte lumbar

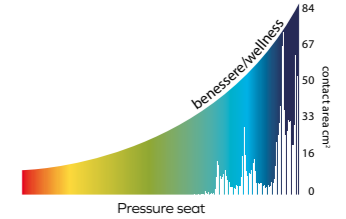

**C** Pressione di bacino e cosce sul sedile  
Hip and thigh pressure on seat  
Pression des cuisses et du bassin sur l'assise  
Druck im Becken und Oberschenkel auf dem Sitz  
Presión de pelvis y muslos en el asiento

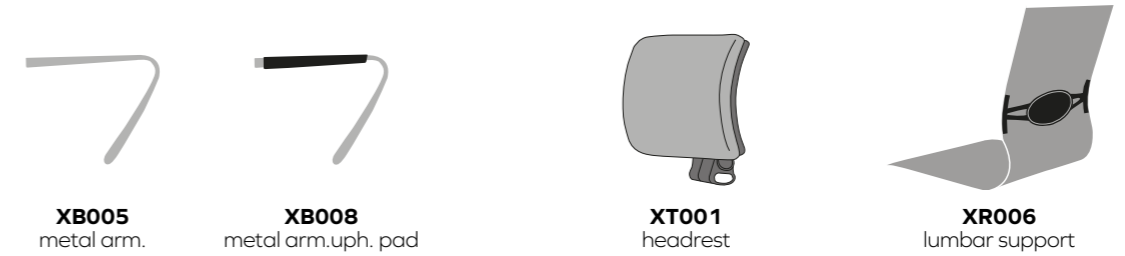
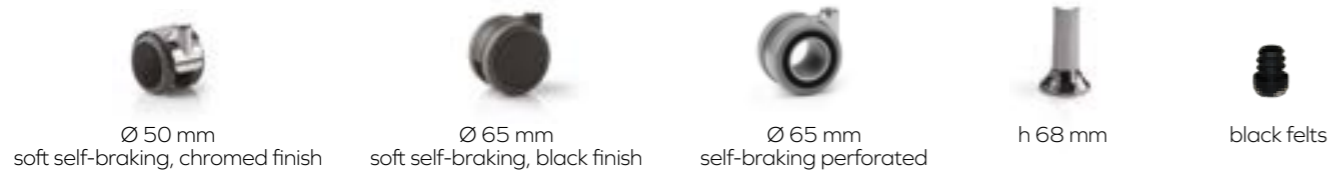
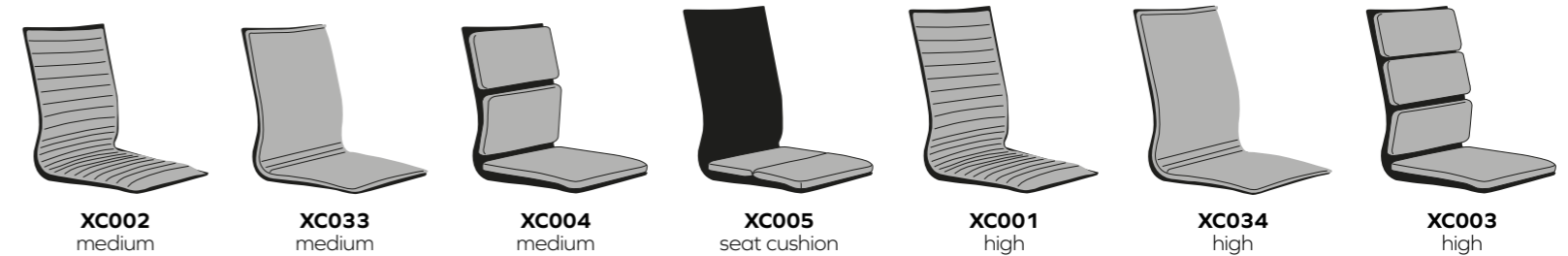

# ALIAC

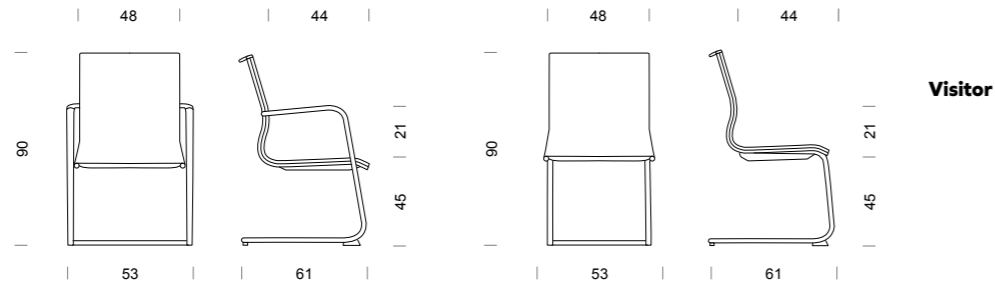

Visitor

**SCHIENALE:**

Monoscocca in tubo sagomato d'acciaio, Ø 25mm, finitura cromata (15µm), rete portante a vista.

**BACKREST:**

Shaped steel tube monocoque, Ø 25mm, chromed finish (15µm), visible load bearing mesh.

**DOSSIER:**

Monocoque en tube d'acier Ø 25mm, finition chromée (15µm). Résille autoportante.

**RÜCKENLEHNE:**

Geförnte Stahlrohrschale, Ø 25mm, verchromt (15µm), mit Netzgespann.

**RESPALDO:**

Monocasco en tubo de acero con forma, Ø 25 mm, acabado cromado (15 µm), malla portante.



visitor base with arms



plugs with felts



**XC002**  
medium



**XC033**  
medium



**XC004**  
medium

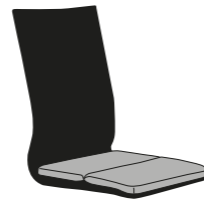

**XC005**  
seat cushion

# ALIAC



ID 1111209614



# ALIA Top



# ALIA Top



# ALIA Top

design AMBOSTUDIO

Tutta la performance del design di AliaC, impreziosita da un rivestimento in morbida pelle e da un doppio traverso, sia sopra lo schienale che sotto la seduta. AliaTop eleva l'ergonomia e il comfort, rendendo di serie un'estetica ancora più sofisticata per uffici dirigenziali, boarding room e ambienti professionali.

*AliaTop guarantees the performance of the AliaC design, while sporting a soft leather upholstery and a double C-shaped bar, one on top of the backrest and the other in the seat. Thanks to its sophisticated details, it brings ergonomics and comfort to the next level for executive offices, boarding rooms and professional spaces.*

Traversi a "C", morbida seduta in pelle.  
Schienale medio o alto.

*C-shaped bars, soft leather seat.  
Medium or high backrest.*



M



ALIA Top



M

34





ALIA Top



ALIA Top



ALIA Top



# ALIATop

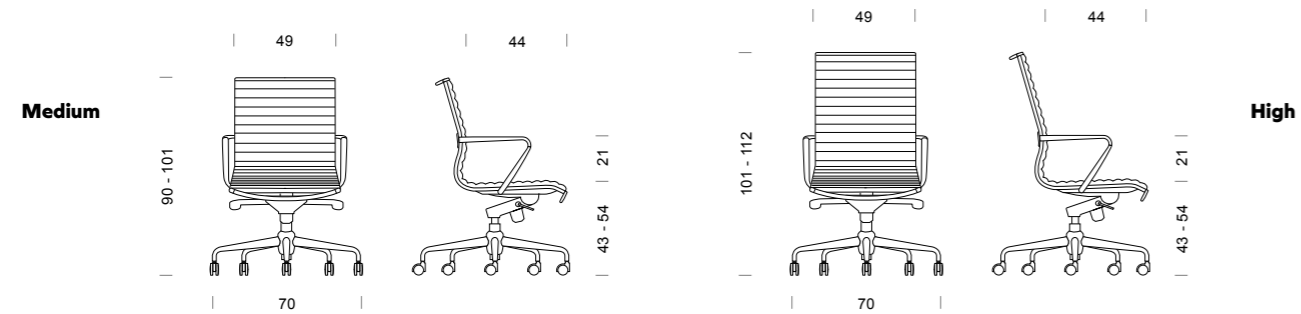

**SCHIENALE:** Monoscocca in tubo sagomato d'acciaio, Ø 25mm, finitura cromata (15µm) rete portante, imbottita con spugna e rivestita.

**BACKREST:** Shaped steel tube monocoque, Ø 25mm, chromed finish (15µm), load bearing Mesh. Foam padded and upholstered.

**DOSSIER:** Monoque en tube d'acier Ø 25mm, finition chromée (15µm). Résille autoportante rembourrée de mousse et tapissée.

**RÜCKENLEHNE:** Geformtes Stahlrohr Gestell, Ø 25mm, verchromt (15µm) mit Netzgespann und gesteppte Polsterung.

**RESPALDO:** Monocasco en tubo de acero perfilado, Ø 25 mm, acabado cromado (15 µm), malla portante acolchada con espuma y tapizada.

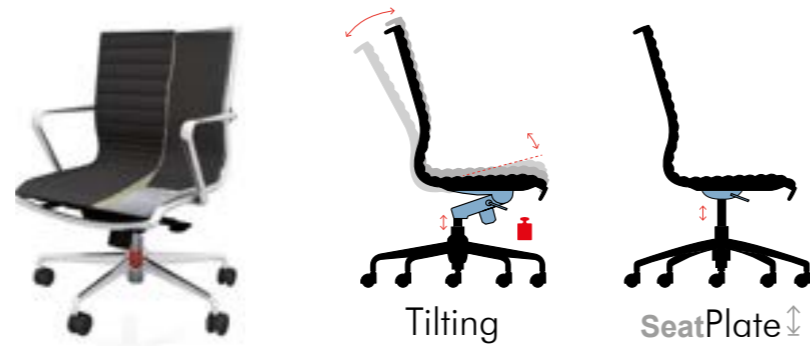

5-spoke aluminium base



5-spoke iron base



Ø 50 mm soft self-braking, chromed finish



Ø 65 mm soft self-braking, black finish



**XB005** metal arm.



**XB008** metal arm. uph. pad



visitor base with arms



plugs with felts



**XH001** uph. pad



**A** Pressione sullo schienale di spalle e scapole  
Shoulders and scapulas pressure on backrest  
Pression des épaules et omoplates sur le dossier  
Druck von der Schulter und Schulterblatt auf der Rückenlehne  
Presión en la parte posterior de los hombros y omóplatos

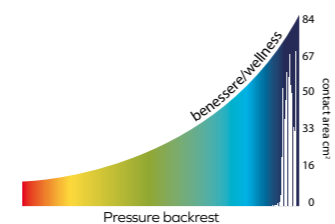

**B** Pressione dell'area sacrale su supporto lombare  
Sacrum pressure on lumbar support  
Pression sacrale sur le soutien lombaire  
Druck im Bereich Kreuzbein und Lendenwirbelstütze  
Presión del área sacra sobre soporte lumbar

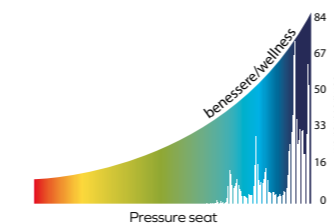

**C** Pressione di bacino e cosce sul sedile  
Hip and thigh pressure on seat  
Pression des cuisses et du bassin sur l'assise  
Druck im Becken und Oberschenkel auf dem Sitz  
Presión de pelvis y muslos en el asiento

# ALIATop

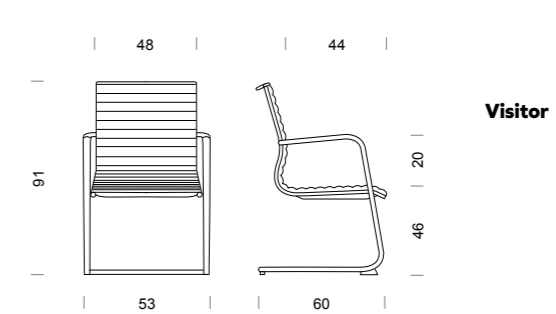

**SCHIENALE:** Monoscocca in tubo sagomato d'acciaio, Ø 25mm, finitura cromata (15µm), rete portante, imbottita con spugna e rivestita.

**BACKREST:** Shaped steel tube monocoque, Ø 25mm, chromed finish (15µm). Load bearing Mesh. Foam padded and upholstered.

**DOSSIER:** Monoque en tube d'acier Ø 25mm, finition chromée (15µm). Résille autoportante rembourrée de mousse et tapissée.

**RÜCKENLEHNE:** Geformte Stahlrohrschale, Ø 25mm, verchromt (15µm), mit Netzgespann und gesteppte Polsterung.

**RESPALDO:** Monocasco en tubo de acero perfilado, Ø 25 mm, acabado cromado (15 µm), malla portante acolchada con espuma y tapizada.



ID 1111209614



ID 1111209602



# AURELIA



# AURELIA



# AURELIA

by PIETRO LOVATO

Aurelia rappresenta la poltrona direzionale classica: imponente e generosa nelle forme. La cura minuziosa dei dettagli realizzativi e la scelta dei materiali ne fanno una seduta solida e avvolgente da inserire in contesti prestigiosi.

*Aurelia represents the typical executive chair: majestic with ample cushions. The meticulous attention to each detail and the choice of materials make it a solid seat which provides softness and comfort even in the most prestigious environments.*

Struttura in metallo, scocca in poliuretano.  
Schienale medio o alto.

*Metal structure, polyuretane shell.  
Medium or high backrest.*



M



AURELIA DUCALE



AURELIA IMPERIALE



AURELIA IMPERIALE



AURELIA REGALE



M

AURELIA REGALE



# AURELIA

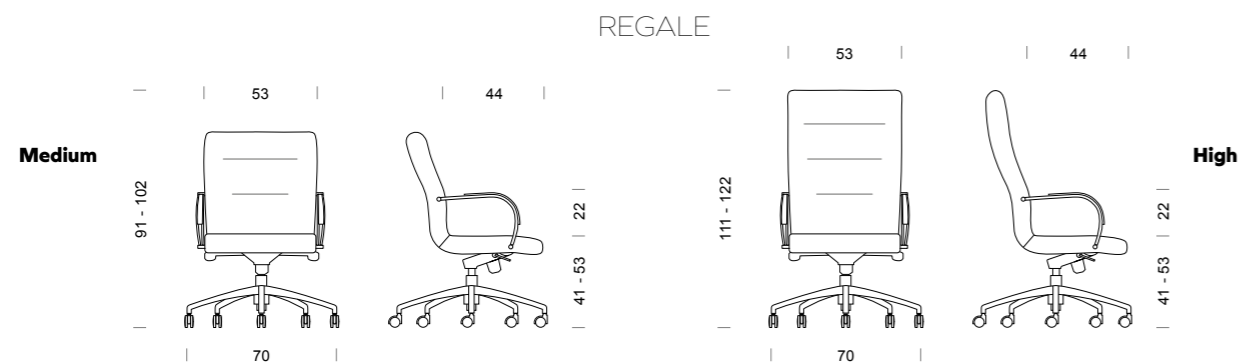
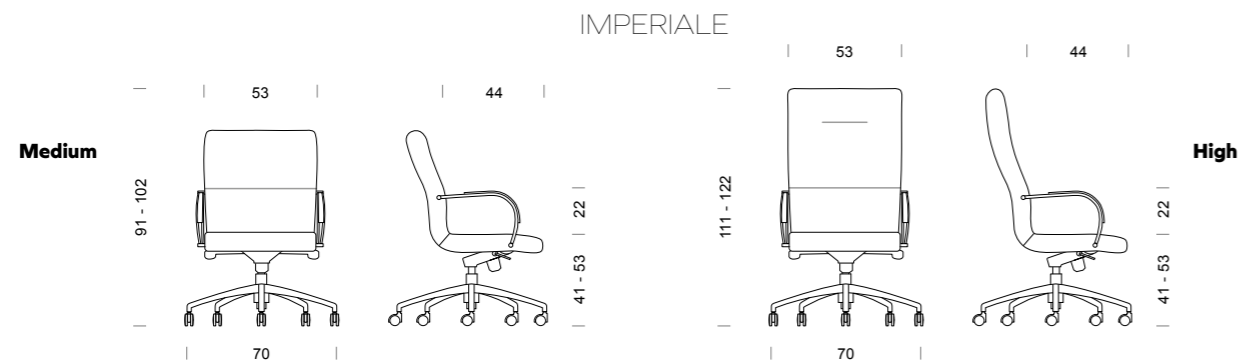
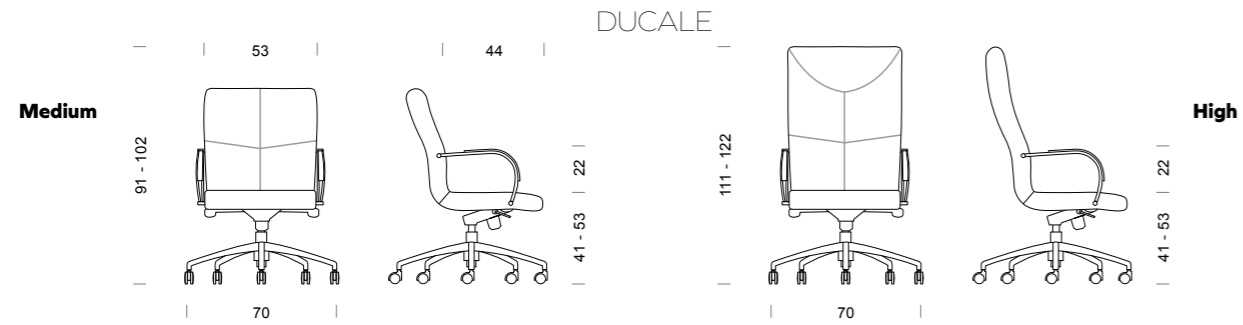

# AURELIA

**SCHIENALE:**  
Monoscocca in spugna schiumata a freddo con struttura portante in tubo tondo d'acciaio, Ø 20mm, rivestita in tessuto.

**BACKREST:**  
Cold injected foam padding monocoque, Ø 20mm steel tube structure, fabric upholstery.

**DOSSIER:**  
Monocoque en mousse moulée à froids avec châssis en tube d'acier rond, Ø 20mm, tapissée.

**RÜCKENLEHNE:**  
Stahlrohrstruktur Ø20mm, mit Kaltgeschäumten Polyurethan, ausgepolstert.

**RESPALDO:**  
Monocasco en espuma inyectado a frio con estructura de soporte en tubo de acero redondo, Ø 20 mm, tapizado.

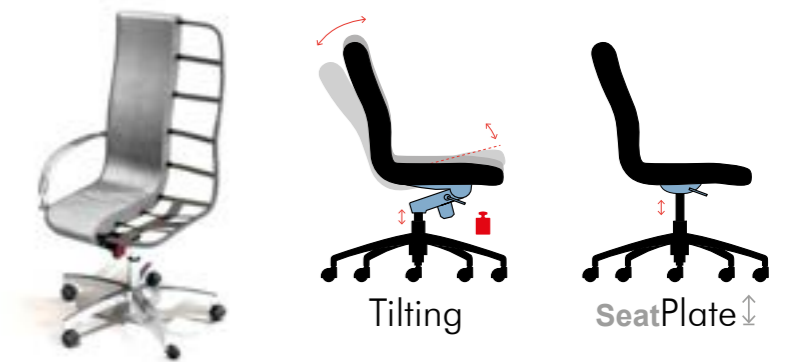

5-spoke aluminium base



Ø 50 mm self-braking, black finish



Ø 50 mm soft self-braking, black finish



**XB067**  
metal arm. black polyurethane pad  
**XB068**  
metal arm. uph. pad

# AURELIA

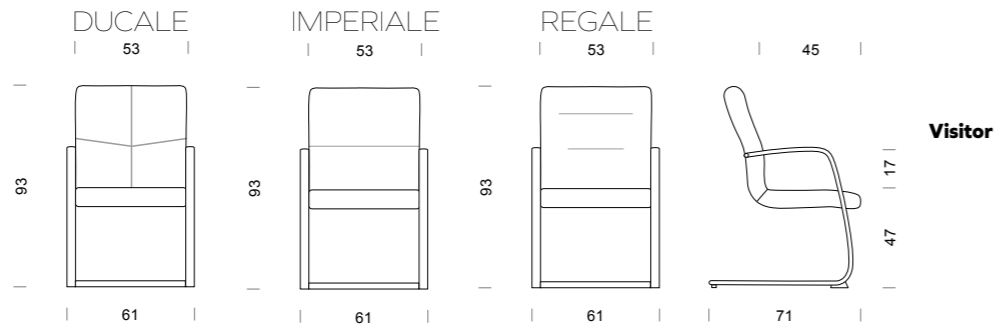

**SCHIENALE E SEDILE:**

Monoscocca in spugna schiumata a freddo con struttura portante in tubo tondo d'acciaio, Ø 16mm, rivestita in tessuto.

**BACKREST AND SEAT:**

Cold injected foam padding mono-coque, Ø 16mm steel tube structure, fabric upholstery.

**DOSSIER ET ASSISE:**

Monocoque en mousse moulée à froids avec châssis en tube d'acier rond, Ø 16mm, tapissée.

**RÜCKENLEHNE, SITZ:**

Stahlrohrgestell Ø20mm, mit kaltgeschäumte Polyurethan Schale.

**RESPALDO:**

Monocasco en espuma inyectado a frio con estructura de soporte en tubo de acero redondo, Ø 16 mm, tapizado.



visitor base with arms



polyamide plugs  
black finish



**XH007**  
uph. pad



# AURELIA DUCALE



VIVA



# VIVA



# VIVA

by PIETRO LOVATO

Viva è una sedia direzionale dalle forme rigorose con un originale tocco di eleganza dovuto al profilo cromato dei braccioli che corre dietro lo schienale. L'opzione del bracciolo interamente rivestito le regala un'immagine di solidità e imponenza ancora maggiore.

*Viva is a classic executive chair with an original touch of elegance provided by the chromed armrest profile which runs behind the backrest. The fully upholstered armrest version conveys an even greater image of solidity and majesty.*

Linee classiche e imbottitura in morbida pelle.  
Schienale alto.

*Classic design and smooth leather upholstery.  
High backrest.*

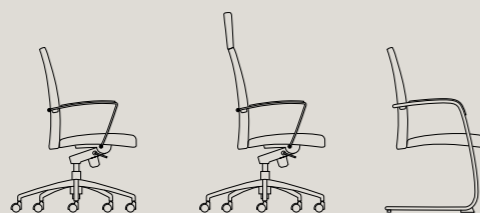

M





VIVA



VIVA



M

VIVA





VIVA



VIVA



VIVA



# VIVA

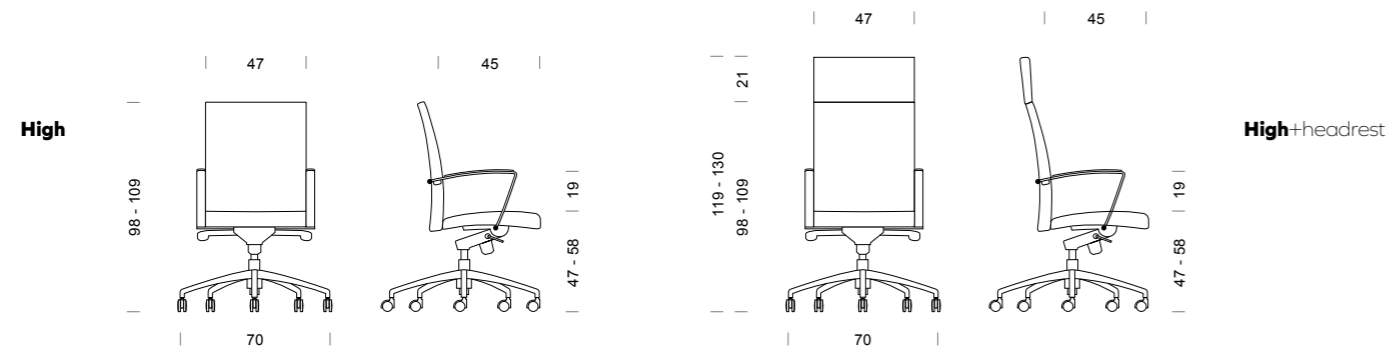

### SCHIENALE:

Schienale in spugna schiumata a freddo con struttura portante in tubo quadro d'acciaio, 15x15mm, con fasce elastiche, rivestita.

### BACKREST:

Cold injected foam padded backrest steel square tube, 15x15mm structure, with elastic bands, upholstery.

### DOSSIER:

Dossier en mousse moulée à froids avec châssis en tube d'acier carré, 15x15mm, avec bandes élastiques, tapissé.

### RÜCKENLEHNE:

Vierkantstahlrohr Struktur 15x15mm mit elastische Bänder. Ausgepolstert mit kaltgeschäumte Polyurethan und Stoffbezug.

### RESPALDO:

Respaldo de espuma inyectado a frio con estructura de soporte en tubo de acero cuadrado, 15x15mm, con bandas elásticas tapizado.

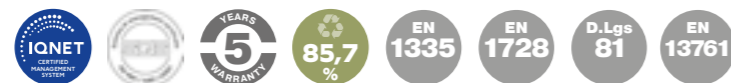
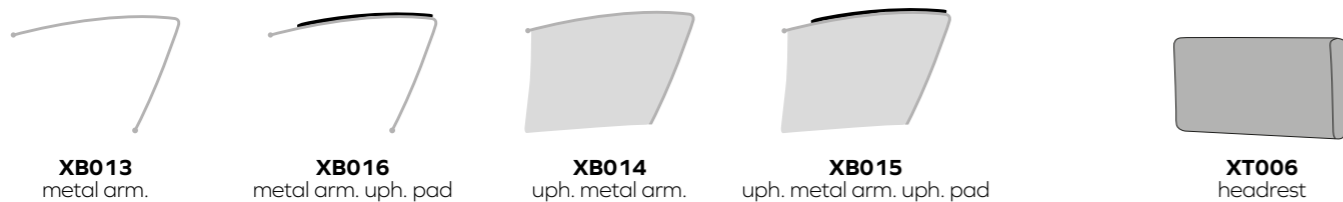
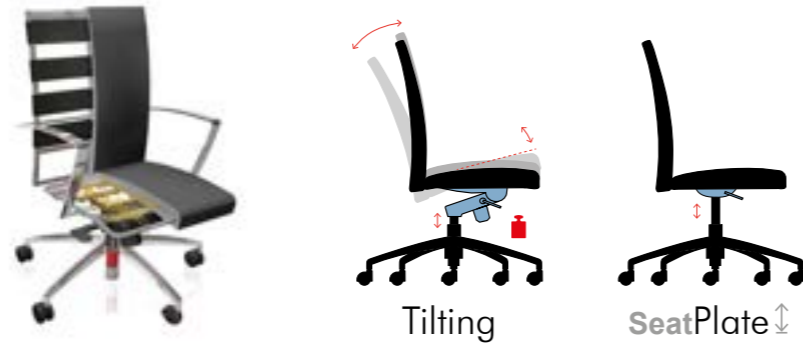

# VIVA

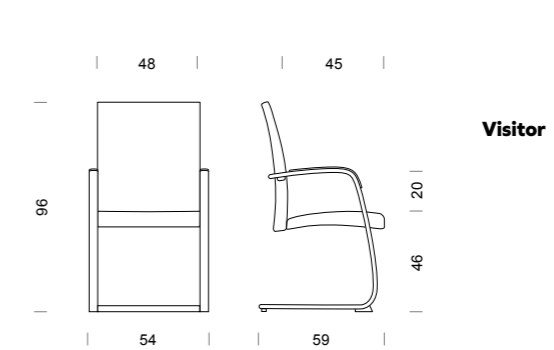

### SCHIENALE:

Schienale in spugna schiumata a freddo con struttura portante in tubo quadro d'acciaio, 15x15mm, rivestita.

### BACKREST:

Cold injected foam padded backrest steel square tube, 15x15mm structure, upholstery.

### DOSSIER:

Dossier en mousse moulée à froids avec châssis en tube d'acier carré, 15x15mm, tapissé.

### RÜCKENLEHNE:

Kaltgeschäumten Polyurethan Rückenlehne. Vierkantstahlrohr 15x15mm.

### RESPALDO:

Respaldo de espuma inyectado a frio con estructura de soporte en tubo de acero cuadrado, 15x15mm, tapizado.



**A** Pressione sullo schienale di spalle e scapole  
Shoulders and scapulas pressure on backrest  
Pression des épaules et omoplates sur le dossier  
Druck im Bereich Kreuzbein und Lendenwirbelstütze  
Presión en la parte posterior de los hombros y omóplatos

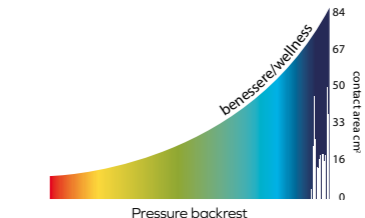

**B** Pressione dell'area sacrale su supporto lombare  
Sacrum pressure on lumbar support  
Pression sacrale sur le soutien lombaire  
Druck im Bereich Kreuzbein und Lendenwirbelstütze  
Presión del área sacra sobre soporte lumbar

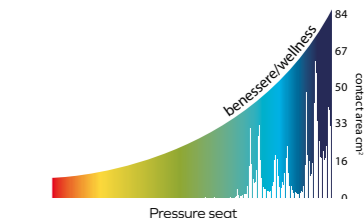

**C** Pressione di bacino e cosce sul sedile  
Hip and thigh pressure on seat  
Pression des cuisses et du bassin sur l'assise  
Druck im Becken und Oberschenkel auf dem Sitz  
Presión de pelvis y muslos en el asiento



# MOVING

Dal 1980 MOVING progetta e realizza sedie ergonomiche di alta qualità nel suo stabilimento di Trissino, Vicenza. La tradizione artigianale e l'approccio innovativo caratterizzano ogni prodotto che l'azienda propone per l'ufficio, la casa e gli spazi comuni, perchè il benessere delle persone incontra la funzionalità e l'estetica.

*Since 1980 MOVING has designed and manufactured high quality seats at their facilities in Trissino, in the Northeast Italy. Traditional craftsmanship and an innovation-driven approach characterise the brand's products, a wide range of solutions for office spaces, home and public spaces, so that wellbeing meets functionality and aesthetics.*

*Depuis 1980, MOVING conçoit et fabrique des sièges de haute qualité dans l'usine de Trissino, dans le nord-est de l'Italie. L'artisanat traditionnel et une approche axée sur l'innovation caractérisent les produits de la marque, comprenant une large gamme de solutions pour les espaces de bureau, la maison et les espaces publics, afin que le bien-être rencontre la fonctionnalité et l'esthétique.*

*Seit 1980 entwickelt und produziert Moving in seinem Werk in Trissino, Vicenza, hochwertige, ergonomische Stühle. Die handwerkliche Tradition und der innovative Ansatz, kennzeichnen jedes Produkt das das Unternehmen für Büro, Wohnbereich und Gemeinschaftsräume anbietet, damit das Wohlbefinden des Benutzers Funktionalität und Ästhetik trifft.*

*Desde 1980, Moving diseña y produce sillas ergonómicas de alta calidad en su planta de Trissino, Vicenza. La tradición artesanal y el enfoque innovador caracterizan todos los productos que la empresa ofrece para la oficina, el hogar y otros entornos donde el bienestar de las personas se encuentra con la funcionalidad y la estética.*

[movingchairs.it](http://movingchairs.it)

MOVING srl  
Via dell'Artigianato 1  
Trissino (VI) Italy  
T +39 0445 490777  
[info@moving.vi.it](mailto:info@moving.vi.it)

© all rights reserved MOVING srl. Made in Italy September 2024  
Any reproduction of this document, even partial, is prohibited without the prior authorisation of the company MOVING srl.

Photographic techniques do not allow perfect reproduction of color shades, which should therefore be considered as purely indicative. Printed colors on leather or fabrics may vary.

